

ESi161

1600kg

Pedestrian Double-deck Stacker



EP
Let's grow together

- Multipurpose mono mast Li-Ion battery stacker with initial lifting
- Double lifting allow to move 2 pallets at the time and easily drive on ramps and uneven floor
- Central driving with stabilizing wheels for better handling, traction and stability
- Turtle button to operate in narrow spaces
- Fast charging trough integrated charger



Manufacturer			EP
Model designation			ESi161
Drive			Electric
Load capacity	Q	kg	1600
Load center distance	c	mm	600
Service weight		kg	510
Lift height	h3	mm	1520
Height, mast extended	h4	mm	1986
Initial lift	h5	mm	115
Length to face of forks	l2	mm	620
Overall width	b1/b2	mm	800
Fork dimensions	s/e/l	mm	55/190/1150
Turning radius	Wa	mm	1473
Max. gradeability, laden/unladen		%	3/10
Travel speed, laden/unladen		km/h	4/4.5
Lifting speed, laden/unladen		m/s	0.1/0.12
Lowering speed, laden/unladen		m/s	0.1/0.07
Battery voltage/nominal capacity		V/Ah	24/100

EP EQUIPMENT CO.,LTD
www.ep-equipment.com

V2412.02

FEATURES

■ All round visibility ensuring safety and precision

The mono mast with a transparent panel offers an optimal view of the fork tips, which ensures precise stacking and retrieval safety.

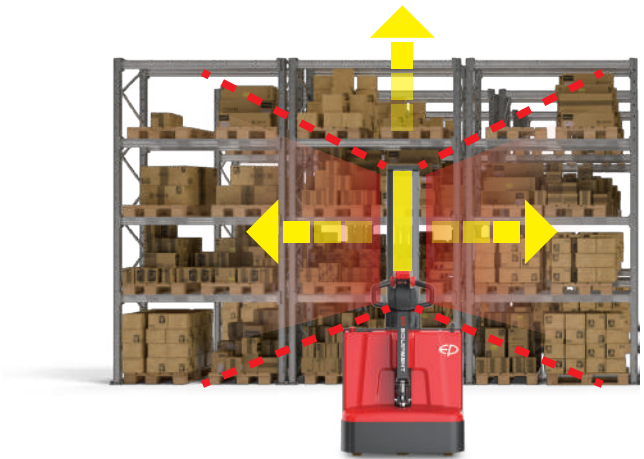

■ Compact design and turtle button for great maneuverability

The compact chassis and the turtle button qualify ESi161 for high maneuverability when loading and unloading in confined spaces or lorries.



■ Lithium technology with integrated charger

The ESi161 adopts a Li-ion battery and an integrated charger as standard to increase uptime thanks to flexible and fast charging support.

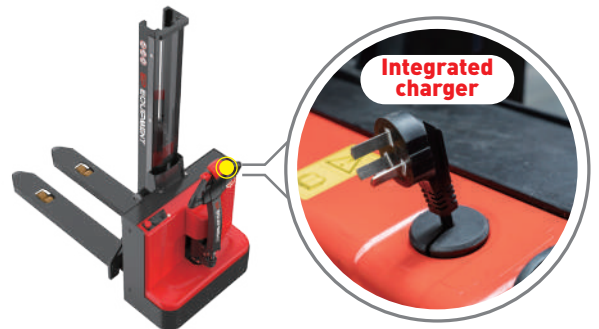

■ Middle drive wheel for easy traction and operation

The ESi161 demonstrates higher maneuverability in narrow aisles due to the centralized drive wheel. The truck provides better traction compared to the ones with offset drives.



Li-ion Pedestrian Double-deck Stacker 1.6T

ESi161

Distinguishing mark	1.1	Manufacturer			EP
	1.2	Model designation			ESi161
	1.3	Drive			Electric
	1.4	Operator type			Pedestrian
	1.5	Load capacity	Q	kg	1600
	1.5.1	Load capacity, load with mast lift	Q1	kg	800
	1.5.2	Load capacity, load with support arm lift	Q2	kg	1600
	1.6	Load center distance	c	mm	600
	1.8	Load distance, centre of drive axle to fork	x	mm	798
	1.9	Wheelbase	y	mm	1265
Service weight	2.1	Service weight		kg	510
	2.2	Axle loading, laden front/rear		kg	550/1560
	2.3	Axle loading, unladen front/rear		kg	375/135
Tyres/chassis	3.1	Tyre type			Polyurethane
	3.2.1	Tyre size, front		mm	Ø210×70
	3.3.1	Tyre size, rear		mm	Ø80×61
	3.4	Additional wheels (castor wheels)		mm	Ø130×55
	3.5	Wheels, number front/rear (x=drive wheels)		mm	1, 2 / 4
	3.6.1	Tread width, front	b10	mm	592
	3.7.1	Tread width, rear	b11	mm	370
Dimensions	4.0	Max. Lift Height	H	mm	1608
	4.2	Retracted mast height	h1	mm	1942
	4.3	Free lift	h2	mm	1515
	4.4	Lift height	h3	mm	1520
	4.5	Height, mast extended	h4	mm	1986
	4.6	Initial lift	h5	mm	115
	4.9	Height of tiller handle in drive position min./max.	h14	mm	800/1190
	4.10	Height of wheel arms	h8	mm	—
	4.15	Lowered height	h13	mm	91
	4.19	Overall length	l1	mm	1770
	4.20	Length to face of forks	l2	mm	620
	4.21	Overall width	b1/b2	mm	800
	4.22	Fork dimensions	s/e/l	mm	55×190×1150
	4.24	Fork carriage width	b3	mm	680
	4.25	Distance between fork-arms	b5	mm	560
	4.26	Distance between wheel arms/loading surfaces	b4	mm	—
	4.31	Ground clearance, laden, below mast	m1	mm	—
4.32	Ground clearance, center of wheelbase	m2	mm	33	
4.34.1	Aisle width for pallets 1000×1200 crossways	Ast	mm	2306	
4.34.2	Aisle width for pallets 800×1200 lengthways	Ast	mm	2240	
4.35	Turning radius	Wa	mm	1473	
Performance data	5.1	Travel speed, laden/unladen		km/ h	4/4.5
	5.2	Lifting speed, laden/unladen		m/s	0.1/0.12
	5.3	Lowering speed, laden/unladen		m/s	0.1/0.07
	5.8	Max. gradeability, laden/unladen		%	3/10
	5.10	Service brake			Electromagnetic
Electric-engine	6.1	Drive motor rating S2 60 min		kW	0.75
	6.2	Lift motor rating at S3 15%		kW	2.2
	6.4	Battery voltage/nominal capacity		V/Ah	24/100
	6.5	Battery weight		kg	28
	6.6	Energy consumption according to DIN EN 16796		kWh/h	0.4
	6.7	Turnover output according to VDI 2198		t/h	22.73
	6.8	Turnover efficiency according to VDI 2198		t/kWh	63.72
	6.8	Turnover efficiency according to VDI 2198		t/kWh	63.72
Addition data	8.1	Type of drive control			DC
	10.5	Steering design			Mechanical
	10.7	Sound pressure level at the driver's ear		dB(A)	74
	15.1	Charger output current		A	30

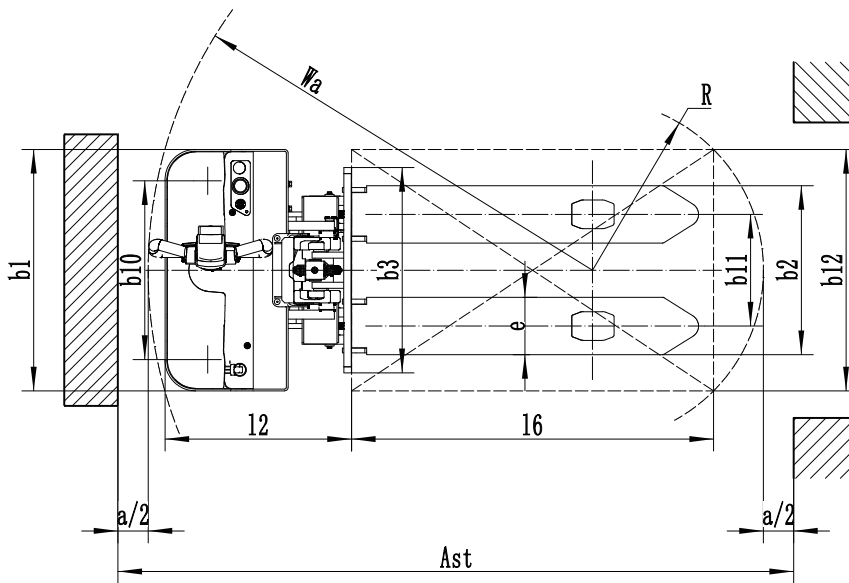
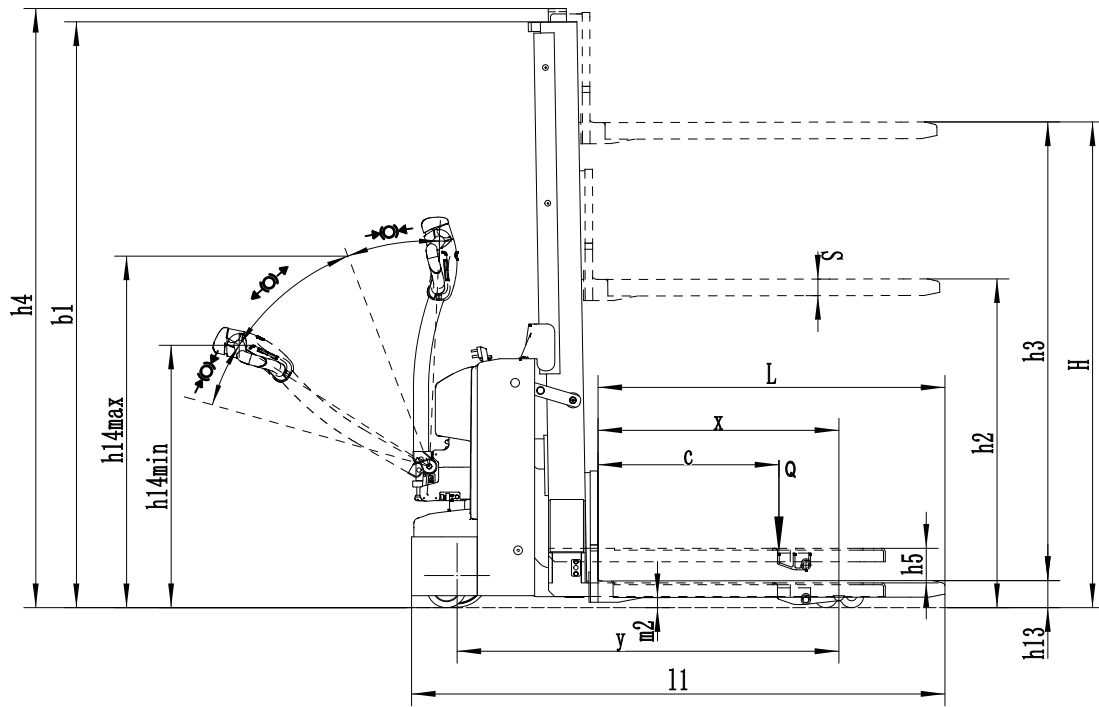

Mast Option:

Mast types	Lift height h_3+h_{13} (mm)	Height, mast lowered h_1 (mm)	Free lift h_2 (mm)	Height, mast extended h_4 (mm)
Simplex Mast	1608	1942	1515	1986

Option:

Optional items	ESi61
Fork dimension	●560*1150
Fork carriage width	●680mm
Load wheel type	●Double
Load wheel material	●Polyurethane
Drive wheel material	●Polyurethane
Battery capacity	●100Ah
Charger	●24V-30A internal
Battery display indicator (BDI)	●With hourmeter
Tiller head type	●ET big tiller head
Castor wheels	●Yes and not customized
Vertical handle: Creep speed	●Yes and not customized
Note: ●Standard ○ Optional - Inconformity	